



Companion Guide

Health Care Claim

**837 Companion Guide
Professional**

**Refers to the ASC X12N 837
Technical Report Type 3 Guide
(Version 005010X222)**

April 2014

Disclosure Statement

It is the sole responsibility of the provider/vendor to initiate all transactions.

Health plans are dynamic; the data included in these transactions is deemed true and accurate only at the particular time of the transaction. Any questions regarding the data should be directed to the Security Health Plan Provider Relations department for claims and/or remittance data.

Preface

This Companion Guide to the v5010 ASC X12N Implementation Guides and associated errata adopted under HIPAA clarifies and specifies the data content when exchanging electronically with Security Health Plan. Transmissions based on this companion guide, used in tandem with the v5010 ASC X12N Implementation Guides, are compliant with both ASC X12 syntax and those guides. This Companion Guide is intended to convey information that is within the framework of the ASC X12N Implementation Guides adopted for use under HIPAA. The Companion Guide is not intended to convey information that in any way exceeds the requirements or usages of data expressed in the Implementation Guides.

Editor's Note:

This page is blank because major sections of a book should begin on a right hand page.

Table of Contents

1 INTRODUCTION 6
Scope..... 6
Overview 6
References 6
Additional Information 6

2 GETTING STARTED..... 6
Working with Security Health Plan 6
Trading Partner Registration 6
Certification and Testing Overview..... 6

3 TESTING WITH THE PAYER 6

4 CONNECTIVITY WITH THE PAYER/COMMUNICATIONS 7
Process Flows 7
Transmission Administrative Procedures 7
Re-Transmission Procedure 7
Communication Protocol Specifications 7
Passwords..... 8

5 CONTACT INFORMATION 8
EDI Customer Service..... 8
EDI Technical Assistance 8
Provider Service Number 8
Applicable Websites/E-Mail..... 8

6 CONTROL SEGMENTS/ENVELOPES 9
ISA-IEA..... 9
GS-GE 10
ST-SE..... 11

7 PAYER SPECIFIC BUSINESS RULES AND LIMITATIONS 12

8 ACKNOWLEDGEMENTS AND/OR REPORTS 12
Report Inventory..... 12

9 TRADING PARTNER AGREEMENTS 12
Trading Partners..... 12

10 TRANSACTION SPECIFIC INFORMATION..... 12

APPENDICES 16
Implementation Checklist 16
Business Scenarios 16
Transmission Examples 17
Frequently Asked Questions 17
Change Summary 17

1 INTRODUCTION

Scope

This Companion Guide has been designed to describe to Security Health Plan's trading partners the format and data content of the Health Care Claims: Professional 837 transaction set in the Electronic Data Interchange (EDI) environment. The 837 claims transaction is used to convey information related to professional claims and/or encounters.

Overview

The Council for Affordable and Quality Healthcare (CAQH) created the Committee on Operating Rules for Information Exchange (CORE). This committee established a common set of operating rules for health care systems which allow providers and other health care systems to implement the CORE operating rules.

References

For more information regarding the ASC X12 Standards for Electronic Data Interchange and to purchase copies of the TR3 documents, consult the Washington Publishing Company web site at <http://www.wpcedi.com/>.

The CORE Phase operating rules are located on the CAQH web site at <http://www.caqh.org>.

Additional Information

Assumes the provider/vendor initiates all transactions.

2 GETTING STARTED

Working with Security Health Plan

Questions related to the 837 transactions should contact Security Health Plan's Provider Relations department at 715-221-9640 or shpprd@securityhealth.org.

Trading Partner Registration

All providers who want to receive 837 transactions should contact Security Health Plan's Provider Relations department at 715-221-9640 or shpprd@securityhealth.org.

Certification and Testing Overview

Testing with the payer is required. You must contact the payer prior to sending all transactions.

3 TESTING WITH THE PAYER

Prior to receiving any transactions from Security Health plan, you must first submit test transactions by contacting Security Health Plan's Provider Relations department at 715-221-9640 or shpprd@securityhealth.org. The Provider Relations department will work with you to ensure that testing has been verified and completed at which time you will be notified that your future transactions will be treated as production.

All test submissions are to be sent in a separate file from normal production transactions. All ASC X12 transactions must use ISA15 (Usage Indicator) to signal whether the data enclosed in the interchange envelope is test or production.

4 CONNECTIVITY WITH THE PAYER/COMMUNICATIONS

Process Flows

This process flow shows a high level overview of trading partner connectivity to Security Health Plan and illustrates the methods used for connectivity.

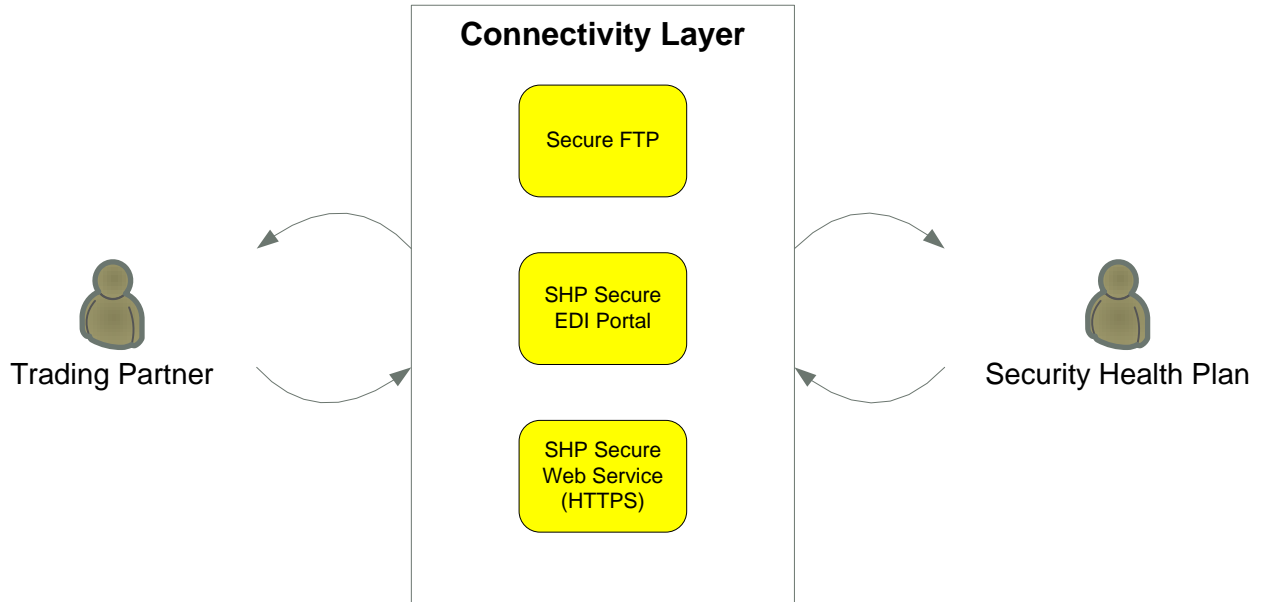

Transmission Administrative Procedures

To receive an 837, enrolled Security Health Plan trading partners will submit X12N 837 transaction data to Security Health Plan for processing. Security Health Plan validates submission of X12N format(s) and processes the transaction data through the claim adjudication system. The 837 transaction will be generated from finalized claims since the last payment cycle.

Re-Transmission Procedure

Transmission/Production Issues

When file transmission or technical production issues occur, which could require the re-submission of files, please contact Security Health Plan's Provider Relations department at 715-221-9640.

Communication Protocol Specifications

SHP Secure EDI Portal

The SHP Secure EDI Portal allows a trading partner to post and retrieve files. A trading partner must be an authenticated portal user. The trading partner accesses the SHP Secure EDI Portal from a web browser and is prompted for a login and password.

Secure FTP

Secure FTP is an appropriate alternative to the SHP Secure EDI Portal for large volume trading partners. For submitting and retrieving files via Secure FTP, access is available free of charge to trading partners. Secure FTP setup will usually occur during trading partner enrollment.

Secure Web Service

Secure Web Service is available to trading partners via HTTPS. For submitting and retrieving files via Secure Web Service, access is available free of charge to trading partners.

Protocol Family: HTTP
Application Protocol: HTTPS
HTTP Language: HTML
HTTP Method: POST
HTML element for “X12 transaction data”: payload

Passwords

Trading Partner ID

The Trading Partner ID links the trading partner to their transaction data and is the Security Health Plan’s internal key to accessing their trading partner information.

Login Credentials

In order to receive your authorized user login credentials, all trading partners, regardless of submission method, must be enrolled with Security Health Plan and approved as trading partners. Login credentials include names/ids and passwords, that will be required for the submission of transactions to Security Health Plan. A user ID and password will be assigned for the chosen communication method.

5 CONTACT INFORMATION

Please have the following information available when calling Security Health Plan’s Provider Relations department regarding transmission and production issues:

- Trading Partner ID and Name
- Communication Method
- Login Name for Communication Method
- Any transactional data needed for specific issues regarding transactions

EDI Customer Service

The contact information for customer service is as follows:

- 715-221-9640
- shpprd@securityhealth.org

EDI Technical Assistance

In the event of technical difficulties please call 715-221-9640 or email shpprd@securityhealth.org

Provider Service Number

Security Health Plan’s Provider Relations department should be contacted 715-221-9640 or shpprd@securityhealth.org.

Applicable Websites/E-Mail

CAQH CORE - <http://www.caqh.org>

Washington Publishing Company - <http://www.wpc-edi.com>

ASC X12 guides: <http://store.x12.org/store/>

6 CONTROL SEGMENTS/ENVELOPES

ISA-IEA

This section describes the use of the Interchange Control segments, ISA and IEA. These segments mark the beginning and ending of an interchange. The ISA segment has a fixed length and all the elements within this segment must be populated. This segment includes a description of the expected sender and receiver codes and delimiters. The first element delimiter in the ISA segment is an Asterisk (*) which will be used as the delimiter throughout the transaction. The final character in the ISA segment is a Tilde (~) will be used as the delimiter for each segment in the transaction.

Segment	Element	Name	Code	Definition of Code/Notes
ISA		Interchange Control Header		The ISA is a fixed-length record with fixed-length elements. Note: Deviating from the standard ISA element sizes will cause the interchange to be rejected.
	ISA01	Authorization Information Qualifier	'00'	No Authorization Information Present
	ISA02	Authorization Information	10 'spaces'	Authorization Information
	ISA03	Security Information Qualifier	'01'	Password Qualifier
	ISA04	Security Information		Password
	ISA05	Interchange ID Qualifier of Sender	'ZZ'	Mutually defined
	ISA06	Interchange Sender ID	'390452970'	Interchange Sender ID for Security Health Plan
	ISA07	Interchange ID Qualifier of Receiver	'ZZ'	U.S. Federal Tax Identification Number
	ISA08	Interchange Receiver ID	<Receiver ID>	Interchange Receiver ID
	ISA09	Interchange Date	YYMMDD	Date of the interchange
	ISA10	Interchange Time	HHMM	Time of the interchange
	ISA11	Interchange Control Standards Identifier	'^'	U.S EDI Community of ASC X12, TDCC and UCS
	ISA12	Interchange Control Version Number	'00501'	
	ISA13	Interchange Control Number		Must be identical to IEA02

Security Health Plan 837 Companion Guide (Professional)

	ISA14	Acknowledgement Requested	'0'	No acknowledgement requested
	ISA15	Usage Indicator	'P'	'P': Production Data
	ISA16	Component Element Separator	>	Component element separator is a delimiter and not a data element
IEA		Interchange Control Trailer Segment		
	IEA01	Number of Included Functional Groups	'1'	Functional Group count
	IEA02	Interchange Control Number		Identical to ISA13

GS-GE

This section describes Security Health Plan's use of the functional group control segments. It includes a description of expected application sender and receiver codes. Also included in this section is a description concerning how Security Health Plan expects functional groups to be sent and how Security Health Plan will send functional groups. These discussions will describe how similar transaction sets will be packaged and Security Health Plan's use of functional group control numbers.

Segment	Element	Name	Code	Definition of Code/Notes
GS		Functional Group Header		
	GS01	Functional Identifier Code	'HC'	Health Care Claim Institutional (837)
	GS02	Application Sender's Code		Enter the same value as ISA06, the nine-digit submitter number assigned by Security Health Plan
	GS03	Application Receiver's Code		Enter "SHP" or "39045" for Security Health Plan
	GS04	Date	CCYYMMDD	Date of functional group creation
	GS05	Time	HHMM	Creation time
	GS06	Group Control Number		Identical to GE02
	GS07	Responsible Agency Code	'X'	Accredited Standards Committee X12. Value should always be 'X'.
	GS08	Version/Release/Industry Identifier Code	'005010X222'	Standards Approved for Publication by ASC X12 Procedures Review Board

Security Health Plan 837 Companion Guide (Professional)

				through October 2003
	REF02	Reference Identification		Enter the value "005010X222" to indicate institutional claim.
GE		Functional Group Trailer		
	GE01	Number of Transaction Sets Included	'1'	Number of transactions included
	GE02	Group Control Number		Identical to GS06

ST-SE

This section indicates the beginning and the ending of a transaction set and provides the count of the transmitted segments including the beginning (ST) and ending (SE) segments. These segments also provide a Transaction Set Control Number which must be identical in each segment.

Segment	Element	Name	Code	Definition of Code/Notes
ST		Transaction Set Header		
	ST01	Transaction Set Identifier	'837'	Health Care Claim Institutional
	ST02	Transaction Set Control Number		Transaction Set Control Number. The Transaction set control numbers in ST
SE		Transaction Set Trailer		
	SE01	Transaction Segment Count	<Total Segments>	Total number of segments included in a transaction set including ST and SE segments.
	SE02	Transaction Set Control Number		Transaction Set Control Number. The transaction set control numbers in ST02 and SE02 must be identical.

7 PAYER SPECIFIC BUSINESS RULES AND LIMITATIONS

Many of the data elements detailed in this Companion Guide reflect Security Health Plan's business requirements, but still meet the standard requirements in the ASC X12N Implementation Guide. Inclusion of a "business-required" data field, as defined by this Companion Guide, will aid in the delivery of a positive response from Security Health Plan.

Note on decimal/amount fields: Even though the X12N transaction defines Amount fields as having an 18-byte maximum, there is an additional HIPAA rule that limits all decimal fields to a maximum of 10 characters, including the two implied or reported decimal places. Accordingly, for all decimal or amount fields:

- "123456789012" is not an acceptable amount, because it is greater than 10 bytes.
- "12345678.90" is acceptable because the number of digits is not greater than 10; the decimal point itself is not limited by the rule.
- However, "1234567890" is not acceptable because the X12N engine assumes that a decimal point and succeeding zeroes are implied so that the actual number being communicated is "1234567890.00", which is greater than 10 bytes.
- The 10-byte limitation applies to all decimal or amount fields, including AMT segments, but also including any other fields that hold amounts or decimals, such as 837 SV207, CAS03, CAS06, CAS09, CAS12, CAS15, CAS18, HI01-5, HI02-5, HCP02 and HCP03, etc.

For all fields not listed in these bullets, follow the guidelines in the ASC X12N Implementation Guides (TR3), available at <http://store.x12.org/store/healthcare-5010-consolidated-guides>

8 ACKNOWLEDGEMENTS AND/OR REPORTS

Report Inventory

A proprietary version can be provided electronically by request.

9 TRADING PARTNER AGREEMENTS

To initiate the evaluation process for potentially becoming a Trading Partner with Security Health Plan, please contact us at 715-221-9640 or shpprd@securityhealth.org

In your request, please include the following information:

- Company Name and Address
- Primary and Alternate Contact Information (Email Address and Phone Numbers)

Trading Partners

An EDI Trading Partner is defined as any Security Health Plan customer (provider, billing service, software vendor, etc.) that transmits to, or receives electronic data from Security Health Plan.

10 TRANSACTION SPECIFIC INFORMATION

This section contains data clarifications, including Security Health Plan-specific data requirements. For additional guidance on the use of business rules, please see Section 7.

Security Health Plan 837 Companion Guide (Professional)

Header

Loop 1000A - Submitter Name

Segment	Element	Industry Name	Comments
Payer Identification (N1)			
NM1	NM101	Entity identifier code	Enter the value "41" for submitter
	NM108	Identification code qualifier	Enter the value "46" for electronic transmitter identification number
	NM109	Submitter identifier	Enter the same value as ISA06, the nine-digit submitter number assigned by Security Health Plan
Administrative Communications Contact (PER)			
PER	PER02	Name	'LARRY STARGARDT'
PER	PER03	Communication Number Qualifier	'TE'
PER	PER04	Communication Number	'7152218337'

Loop 1000B - Receiver Name

Segment	Element	Industry Name	Comments
Receiver Name (NM1)			
NM1	NM101	Entity identifier code	Enter the value "40" for receiver
	NM102	Entity type qualifier	Enter the value "2" for non-person entity
	NM103	Receiver name	Enter "Security Health Plan"
	NM108	Identification code qualifier	Enter the value "46" for electronic transmitter identification number
	NM109	Identification code or receiver primary identifier	Enter the same value as GS03, "SHP" or "39045" for Security Health Plan

Loop 2010 - Subscriber Detail

Segment	Element	Industry Name	Comments
Subscriber Name (NM1)			
2010AA	NM1	Billing Provider name	Enter information about the billing provider in this loop.
	NM108	Identification code qualifier	Enter the value "XX" for National Provider ID (Type 2) or if NPI is not available use "24" for Employer Identification Number
	NM109	Billing Provider ID	National Provider ID (Type2) or Employer Identification Number

Security Health Plan 837 Companion Guide (Professional)

	REF01	Billing Provider Secondary ID qualifier	If a National Provider ID is included in loop 2010AA NM109, then this segment must be used to pass the Employer Identification Number, use the value "EI"
	REF02	Billing Provider Secondary ID qualifier	Enter the Employer Identification Number
2010BA	NM1	Subscriber name	Enter information about the subscriber/recipient in this loop
	NM108	Identification Code Qualifier	'MI'
	NM109	Identification Code	Enter the recipient's 12-digit Subscriber Number. Security Health Plan Member ID. Note: do not enter any other numbers or letters. Use the SHP identification card.
Payer Name (NM1)			
2010BB	NM1	Payer name	Enter information about the payer in this loop
	NM108	Identification Code Qualifier	'PI'
	NM109	Payer Identification Code	Enter "SHP" for Security Health Plan's Primary Payer Identification
Patient Detail (NM1)			
2010CA	NM1	Patient name	Enter information about the patient in this loop (if different from the subscriber)
	NM108	Identification code qualifier	Enter the value "MI" for patient identification number
	NM109	Patient primary identifier	Enter the patient's Medical History Number (six to eight digits)

Loop 2300 - Claim Information

Segment	Element	Industry Name	Comments
Claim Information			
2300	CLM02	Total claim charge amount	Enter the total billed amount for the entire claim
	CLM05-3	Claim frequency code	The third digit of the type of bill, as defined by the National Uniform Billing committee (NUBC), is the frequency. Use the claim frequency code to indicate if the claim is being submitted for the first time or if it is a replacement/void of a previously adjudicated claim and paid claim. <ul style="list-style-type: none"> • Enter the value "1" to indicate it is the first time a claim is submitted to Security Health Plan. • Enter the value "7" to indicate this claim is replacing a previously submitted

Security Health Plan 837 Companion Guide (Professional)

			claim.
	HI	Health care diagnosis code	Enter the diagnosis in this segment.
	HI01-1	Diagnosis type code	Enter the value “BK” for principal diagnosis.
	HI01-2	Principal	Enter the principal diagnosis code.
	HI02-1	Diagnosis type code	Enter the value “BF” for each additional diagnosis code.
	HI02-2 HI03-2 HI04-2 HI05-2 HI06-2 HI06-2 HI08-2	Diagnosis code	Enter additional diagnosis codes in order of importance.
Other Subscriber Information			
2320	SBR	Other Subscriber Information	Include this loop if the claim will be processed by multiple payers
	CAS	Claim level adjustments	Include this segment when another payer has made payment at the claim level
	AMT	Coordination of benefits (COB) payer paid amount	This segment contains the amount paid on this claim by the payer within this 2320 loop.
	AMT01	Amount qualifier code	Enter the value “D” for payer amount paid.
	AMT02	Payer paid amount	Enter the amount paid on this claim by the payer within this 2320 loop
	AMT	Coordination of benefits (COB) allowed amount	Enter how much the other payer allowed in this segment
	AMT01	Amount qualifier code	Enter the value “B6” for allowed amount
	AMT02	Allowed amount	Enter the other payer’s allowed amount. Note: If the claim was not submitted to another payer, a zero must be used as the allowed amount.
2400	SV101-1	Product or service ID qualifier	Enter the value “HC” for Healthcare common Procedure Coding System (HCPCS).
	SV101-2	Procedure code	Enter the HCPCS/CPT code for the procedures performed.
	SV101-3		Enter the HCPCS/CPT code for the procedures performed.

Security Health Plan 837 Companion Guide (Professional)

	SV101-4	Procedure modifier 2	Enter the HCPCS/CPT code for the procedures performed.
	SV101-5	Procedure modifier 3	Enter the HCPCS/CPT code for the procedures performed.
	SV101-6	Procedure modifier 4	Enter the HCPCS/CPT code for the procedures performed.
	SV102	Line item charge amount	Enter the billed amount for each service line.
	SV103	Unit or basis for measurement code	Enter the value “MJ” for minutes or “UN” for units.
	SV104	Service unit count	Enter the number of minutes or units for the services provided.
	SV105	Place of service	Enter the Place of Service (POS) code.
	SV107-1	Diagnosis code pointer	Enter a value of 1 through 8 corresponding to the primary diagnoses in element HI01-2, HI02-2, HI03-2, HI04-2, HI05-2, HI06-2, HI07-2 or HI08-2.
	SV109	Emergency indicator	Enter the value “Y” if the services were performed as a result of an emergency.
	DTP01	Date/time qualifier	Enter the value “472” for service dates
	DTP02	Date/time period format qualifier	Enter value “D8” to indicate a single date of service or “RD8” to indicate a range of service dates
	DTP03	Service date	Enter the date(s) the procedure was performed
2430	SVD01	Other payer primary identifier	Enter the other payer’s primary identifier if another payer has paid on the service line
	SVD02	Service line paid amount	Enter the amount the other payer paid on the service line
	CAS	Line adjudication information	Include this segment when another payer has made payment at the service line.

APPENDICES

Implementation Checklist

Security Health Plan does not offer an Implementation Checklist for our Trading Partner EDI services. Security Health Plan assists new Trading Partners with enrollment and testing, but a formal implementation checklist is not necessary.

Business Scenarios

Please contact the Security Health Plan Provider Relations Department to discuss your specific EDI related business needs with Security Health Plan, should they not be covered in this guide or other available Security Health Plan transaction companion guides.

Transmission Examples

Please contact the Security Health Plan Provider Relations Department for any question regarding transmission examples.

Frequently Asked Questions

N/A

Change Summary

This is the first Security Health Plan 837 Companion Guide created with the CORE template.